

HL7 Gateway

Gateway Server
QP-993PK

Integrate your patient monitoring system
with the hospital information system



SPECIFICATIONS

HL7 version:

HL7 Version 2.4

Number of beds:

Up to 128 monitors per gateway

Transferred vital data (numeric):

Heart rate, Pulse rate, Respiration rate,
12 x ST level, IBP (systolic, diastolic, and mean),
NIBP (systolic, diastolic, and mean), Temperature,
Delta T, Tb, SpO₂, SvO₂, CCO, Ventilator,
Anesthetic gas, BIS, ETCO₂, FICO₂, ETO₂, FIO₂,
N₂O, O₂, tcPO₂, tcPCO₂, MV, Ppeak, PEEP
(Transferred vital signs depend on the measured parameters.)

Transferred waveforms:

ECG, IBP, respiration wave, EEG, CO₂, pulse (SpO₂),
Flow/Paw, anesthetic gas (O₂, CO₂, N₂O, Agent)
(Transferred waveforms depend on the measured parameters.)
Up to 3 waveforms can be transferred simultaneously.)

Waveform format:

MFER (Medical waveform Format Encoding Rules)
MFER is an ISO standard (ISO/TS 11073-92001).

Capabilities:

- Patient query
- Periodic refresh of patient information
- Periodic output of vital data
- Periodic output of alarm events
- Output of vital data
- Output of recently stored vital data
- Sequential output of waveforms
- Output of full disclosure waveforms
- Output of review data, arrhythmia recall,
ST recall and 12-lead ECG analysis

Hardware and software requirements:

- CPU: Dual-Core Intel® Xeon® Processor 2 GHz x 2
- Memory: 2 GB
- Hard Disk: 140 GB x 2 (RAID 1: Mirroring)
- CD drive
- LAN: 2 x 10/100/1000BASE-TX compatible
- OS: Microsoft® Windows Server® 2003 SP2 R2
- Java: Java™ 2 SDK 1.4.2_08
- Browser: Internet Explorer® 6.0 SP2 or later

Intel and Xeon are trademarks of Intel Corporation in the U.S. and other countries.
Microsoft, Windows Server, and Internet Explorer are registered trademarks of Microsoft Corporation in the United States and other countries.
Java is a trademark of Sun Microsystems, Inc. in the U.S. and other countries.
Other models and trademarks are the property of their respective owners.

This brochure may be revised or replaced by Nihon Kohden at any time without notice.

NIHON KOHDEN

NIHON KOHDEN CORPORATION
1-31-4 Nishiochiai, Shinjuku-ku, Tokyo 161-8560, Japan
Phone +81 (3) 5996-8036 Fax +81 (3) 5996-8100
www.nihonkohden.com

Fighting Disease with Electronics

NIHON KOHDEN

5625 CAT.No.58-005 '08.07.SZ.E

Printed in Japan on Recycled Paper

Full connectivity to the hospital system, HIS, CIS and EMR

Your gateway to the integrated hospital of tomorrow

Nihon Kohden's QP-993PK gateway server enables data communication between the hospital or clinical information system (HIS, CIS) and a Nihon Kohden patient monitoring system. The new gateway server provides strong support for automatic patient charting and a solution for managing EMR (electronic medical records) and anesthesia records.

HL7, the global standard for health care information

The QP-993PK gateway server uses the HL7 (Health Level 7) communication protocol. HL7 is a global standard for communication of health care information between different types of devices and systems.

With the HL7 gateway server, you can enter the patient ID at the bedside monitor and receive the patient information from the HIS. The HL7 gateway server then transfers the monitored data to the HIS and EMR.

In addition to patient information and vital data, the HL7 gateway server can handle alarm history, arrhythmia and ST recall, 12 lead analysis reports, and waveforms*.

*Some limitations apply to transferring waveforms.



System Composition Example

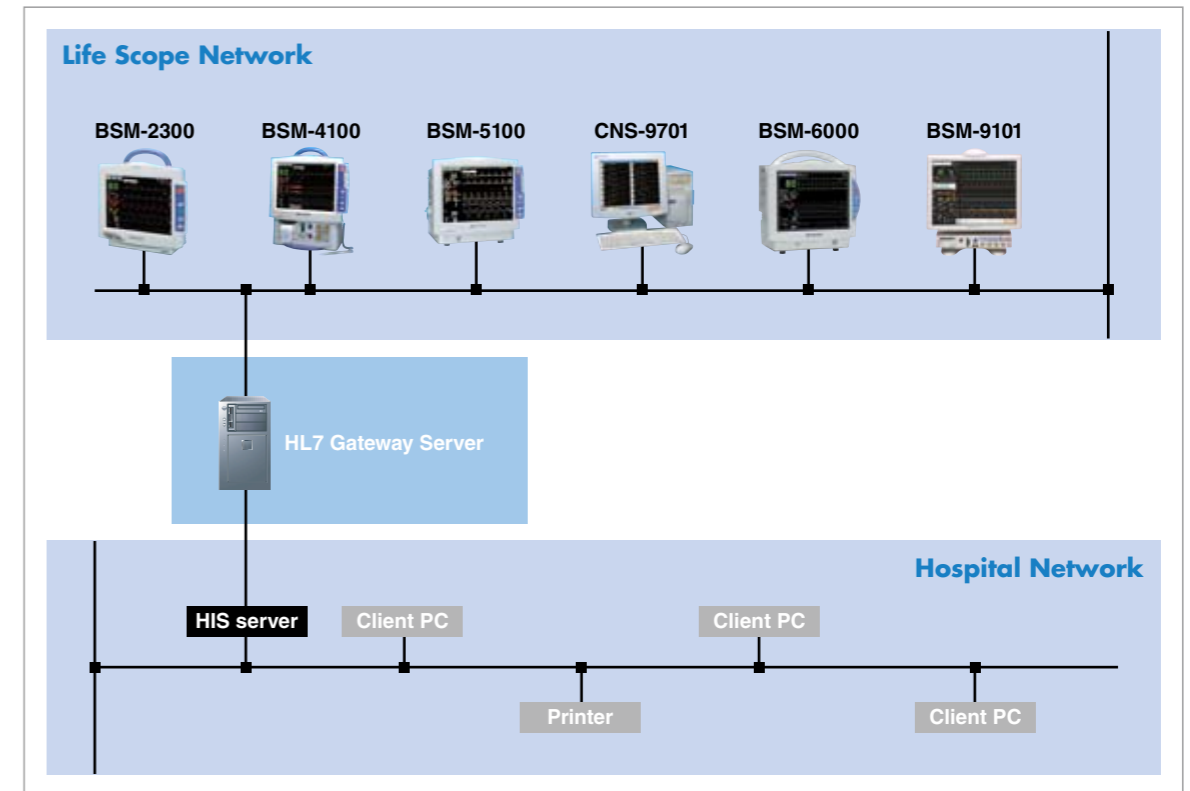

MFER, the new standard for medical waveforms

Waveforms are transferred by the new MFER (Medical waveform Format Encoding Rules) standard. HL7, DICOM or IEEE1073 can also be used to encode medical waveforms but implementation is not always easy. MFER has become the standard in the medical field and it is also an ISO standard, ISO/TS 11073-92001.

MFER is designed to handle medical waveforms simply and easily. It can encode ECG, EEG, respiratory and many other kinds of waveforms. So they can be used by other applications in the hospital or stored in a database.

Supporting the hospitals of today and tomorrow

The HL7 gateway server allows you to integrate the monitoring system with the rest of the hospital's information system. Nihon Kohden offers a gateway to the smoothly integrated hospital of tomorrow.

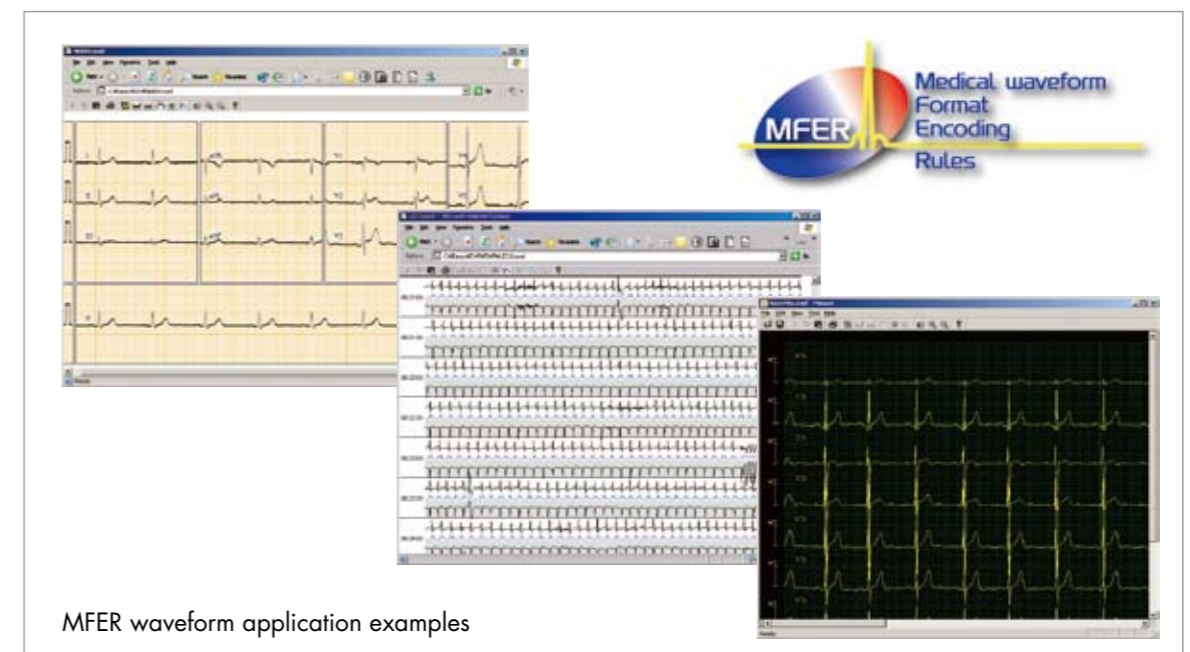

MFER waveform application examples